

# TECHNICAL SPECIFICATIONS

## Zirconia Ceramic Lined Ball Valves

Series 300 ZL-T-H

Sizes 1"-6"



### 1. SCOPE

Composite Ball Valve with Zirconia ceramic liners and ball for severe erosive and corrosive service.

### 2. SERVICE RATING

Temperature rating from -50 to 300° F as shown on pressure/temperature chart on the reverse side. See Catalog 1000 for temperature limits for specific chemicals.

### 3. MATERIALS OF CONSTRUCTION

- (1) **Body:** Graphite Filled Vinyl Ester Composite.
- (2) **Packing Bolts and Gland:** Hastelloy-C with Hastelloy-C gland.
- (3) **Stem:** Hastelloy-C encapsulated with graphite-filled vinyl ester. Solid Hastelloy-C is optional.
- (4) **Stem Packing:** PTFE V-Rings.
- (5) **Seat Retainers:** Graphite Filled Vinyl Ester.
- (6) **Thrust Washer:** Glass and graphite filled PTFE.
- (7) **Ball:** Magnesia-partially stabilized (Mg-PSZ) Zirconia Ceramic.
- (8) **Liners:** Magnesia-partially stabilized (Mg-PSZ) Zirconia Ceramic.
- (9) **Liner Seals:** PTFE coated Viton o-rings.
- (10) **Handle:** Graphite fiber reinforced Nylon 6/6 with locking plate (1"-4"); Stainless steel handle adapter with locking feature (6").

### 4. DESIGN

- Valves shall be flanged and conform to the face-to-face dimensions of ANSI/ASME B16.10.
- Valve shall have integral 4-bolt mounting pads and threaded holes for actuator mounting.
- Stems shall be blowout proof.
- Valves shall have a regular port with ball dimensions as shown on Page 2.
- Flanges shall be flat-faced with serrated finish to allow installation in metallic, lined metal, FRP, and thermoplastic piping systems.
- Flange bolt sizes and spacing shall conform to ANSI B16.5 Class 150. DIN, JIS and BS shall be available.
- Disassembly, maintenance and replacement of any parts shall not require machining or bonding.
- Ball and stem strength shall be sufficient to operate with abrasive particles filling the cavity.

### 5. QUALITY ASSURANCE

- The Manufacturer's facility shall be certified to ISO 9001 or equivalent. The Manufacturer shall be certified to the European Pressure Equipment Directive (PED) and the "CE" mark shall be affixed to each valve label.
- Each valve shall be hydrostatically shell tested at 1.5 x rated CWP for 3 minutes.
- Each valve shall be seat tested with air at 80 psig, or water at 1.1 x rated CWP, in both flow directions. Leakage past the seat shall meet the requirements of ANSI/FCI B16.104 Class IV (.01% of rated Cv).

### 6. PACKING AND SHIPPING

Valves shall be shipped in a closed position with both ends capped to exclude dirt and properly boxed to avoid damage. Each valve shall be marked with the manufacturer, valve size, model, serial number, and valve component designations.

### 7. AVAILABILITY

Valves meeting this specification are available from:

Nil-Cor®, LLC  
12241 Rockhill Avenue, NE  
Alliance, Ohio 44601  
(330) 823-0500  
[www.nilcor.com](http://www.nilcor.com)

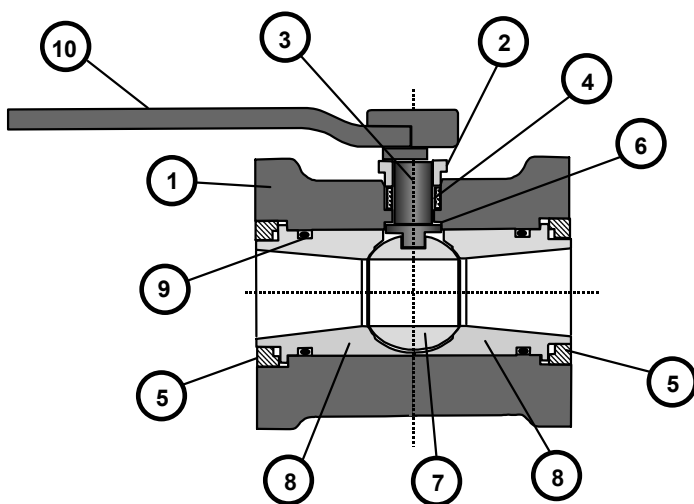

**Pressure-Temperature Rating**  
Nil-Cor Zirconia Ceramic-Lined Ball Valve

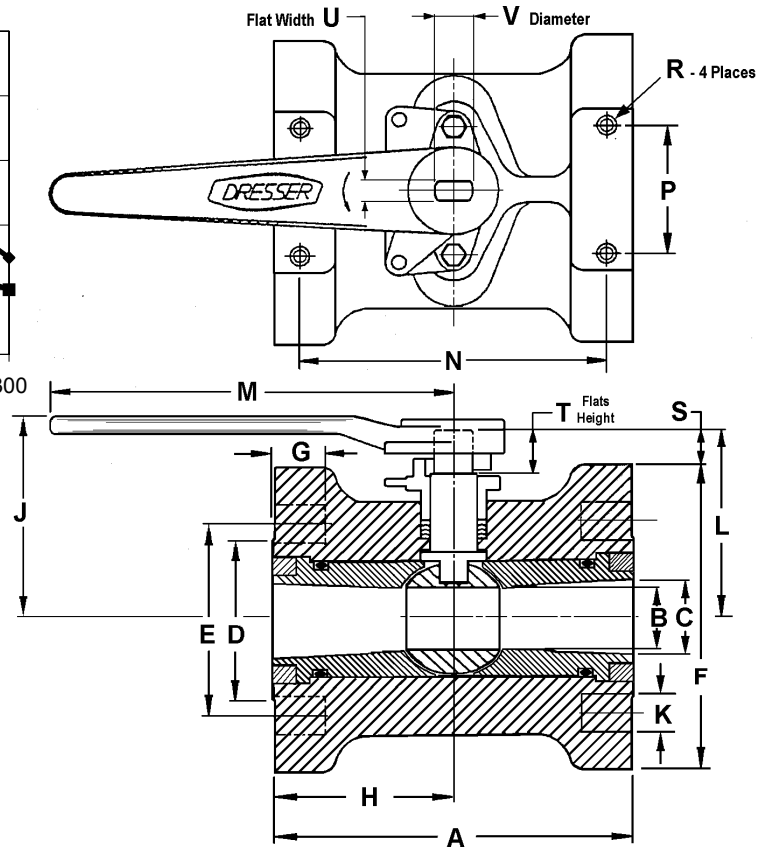
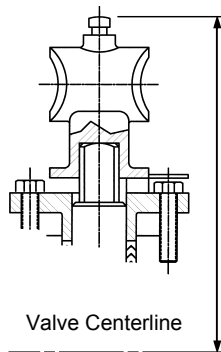
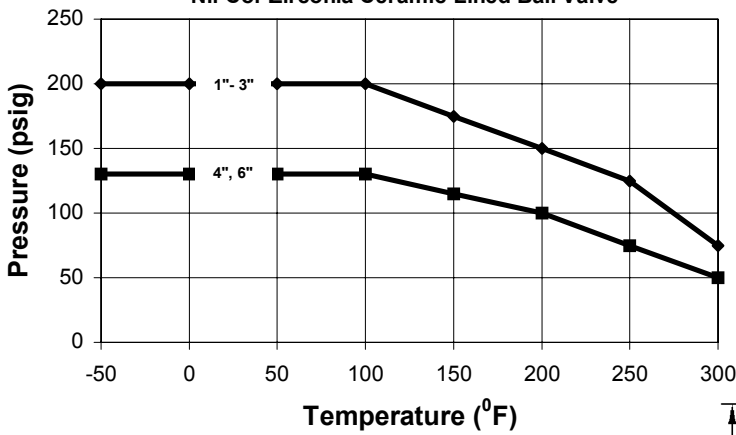

Installation Dimensions													
SIZE	A	B	C	D	E	F	G	H	J	K	K (QTY)	L	M
1"	5.00	.88	1.00	2.25	3.13	4.25	.88	2.50	3.08	.62	4	2.77	6.25
1-1/2"	6.50	1.25	1.50	3.00	3.88	5.00	1.00	3.25	3.73	.62	4	3.55	6.25
2"	7.00	1.50	2.00	3.66	4.75	6.00	1.00	3.50	4.18	.75	4	3.96	9.00
3"	8.00	2.31	3.00	5.00	6.00	7.50	1.36	4.00	5.58	.75	4	5.42	9.00
4"	9.00	3.00	4.00	6.19	7.50	9.00	1.50	4.50	7.05	.75	8	6.50	11.44
6"	10.50	4.50	6.00	8.50	9.50	11.00	1.63	5.25	10.51	.88	8	7.91	*

Actuator Mounting Dimensions								Actuation		
Valve Size	N	P	R x (deep) <sup>1</sup>	S	T	+0.000-.010 U	+0.000-.010 V	Torque (in-lbs.) <sup>2</sup>	Flow Coeff. Max. C <sub>v</sub> <sup>3</sup>	Weight (lbs.)
1	4.18	1.75	5/16 - 18 x 1/2	0.64	0.50	0.375	0.500	160	75	5
1-1/2	5.62	1.75	5/16 - 18 x 1/2	1.05	0.70	0.375	0.500	230	115	8
2	6.18	2.25	5/16 - 18 x 5/8	0.96	0.75	0.375	0.625	270	135	10
3	7.12	3.50	3/8 - 16 x 3/4	1.67	0.75	0.500	0.875	680	350	17
4	8.00	4.00	7/16 - 14 x 7/8	2.00	1.13	0.750	1.000	1250	540	28
6	9.00	5.25	7/16 - 14 x 1-1/8	2.41	1.13	0.750	1.000	2400	1240	47

1. Minimum thread engagement required to develop design joint strength on the actuator mounting pad (composite valve body).
2. Normally expected operating torque for slurry applications. Verify with Nil-Cor on each application.
3. Standard Port configuration. Consult factory for control ball C<sub>v</sub> selections.