

TECHNICAL SPECIFICATIONS
Flanged Ball Valves **Sizes 1" - 4"**
Series 410 Fiberglass Reinforced Polysulfone



1. SCOPE

Ball valves for corrosive chemical service used in construction of pressurized piping systems.

2. SERVICE RATING

Temperature rating from -50 to 300° F as shown on pressure/temperature chart on the reverse side. See Catalog 1000 for temperature limits for specific chemicals.

3. MATERIALS OF CONSTRUCTION

- (1) **Body:** Solid construction of fiberglass and polysulfone resin.
- (2) **Gland:** Hastelloy-C with integral locking plate.
- (3) **Stem:** Hastelloy-C metal insert with molded fiberglass/polysulfone composite on all wetted surfaces.
- (4) **Gland Bolts:** Hastelloy-C
- (5) **Stem Packing:** Chevron style PTFE.
- (6) **Thrust Washer:** Glass and carbon-filled PTFE.
- (7) **Insert:** Solid construction of fiberglass and polysulfone resin.
- (8) **Seals:** PTFE-coated Viton O-ring.
- (9) **Ball:** Solid construction of fiberglass and polysulfone resin.
- (10) **Seats:** Virgin PTFE. Glass-filled and cavity-filler seats available.
- (11) **Handle:** PPA-FRP (1"-4"). All handles have locking provision.

4. DESIGN

- Valves shall be flanged and conform to the face-to-face dimensions of ANSI/ASME B16.10.
- Valve shall have integral 4-bolt mounting pads and threaded holes for actuator mounting.
- Stems shall be blowout proof.
- Valves shall have a regular port with ball dimensions as shown on Page 2.
- Flanges shall be flat-faced with serrated finish to allow installation in metallic, lined metal, FRP, and thermoplastic piping systems.
- Flange bolt sizes and spacing shall conform to ANSI B16.5 Class 150. DIN, JIS and BS shall be available.
- Disassembly, maintenance and replacement of any parts shall not require machining or bonding.
- Ball and stem strength shall be sufficient to operate with abrasive particles filling the cavity.

5. QUALITY ASSURANCE

- The Manufacturer's facility shall be certified to ISO 9001 or equivalent. The Manufacturer shall be certified to the European Pressure Equipment Directive (PED) and the "CE" mark shall be affixed to each valve label.
- Each valve shall be hydrostatically shell tested at no less than 1.43x its rated cold working pressure for 3 minutes.
- Each valve shall be seat tested with air at 20 and 80 psig. The seat test pressure shall be applied successively to each end of the closed valve with the other end open to the atmosphere. No visible leakage shall be permitted for the duration of the tests.

6. PACKING AND SHIPPING

Valves shall be shipped in a closed position with both ends capped to exclude dirt and properly boxed to avoid damage. Each valve shall be marked with the manufacturer, valve size, model, serial number, and valve component designations.

7. AVAILABILITY

Valves meeting this specification are available from:

Nil-Cor[®], LLC
 12241 Rockhill Avenue, NE
 Alliance, Ohio 44601
 (330) 823-0500
www.nilcor.com

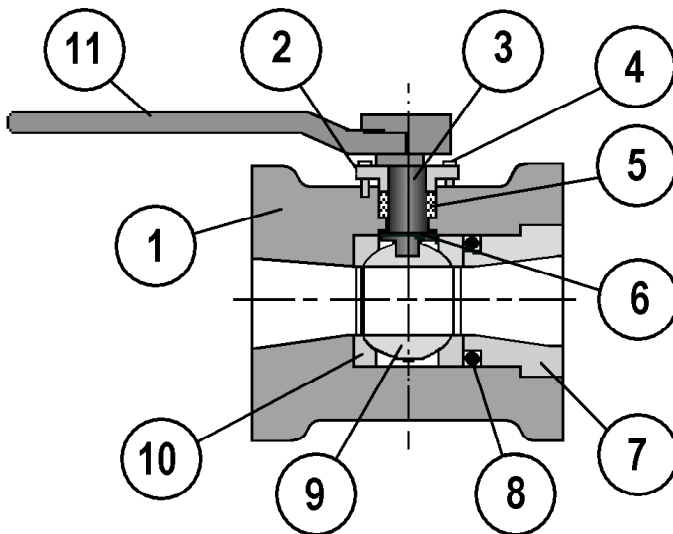

Pressure/Temperature Rating

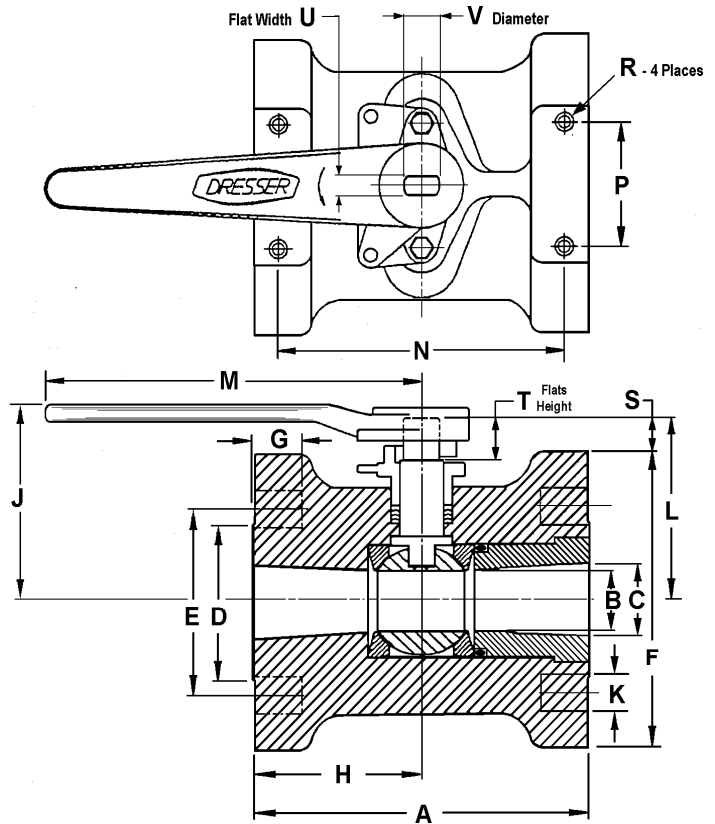
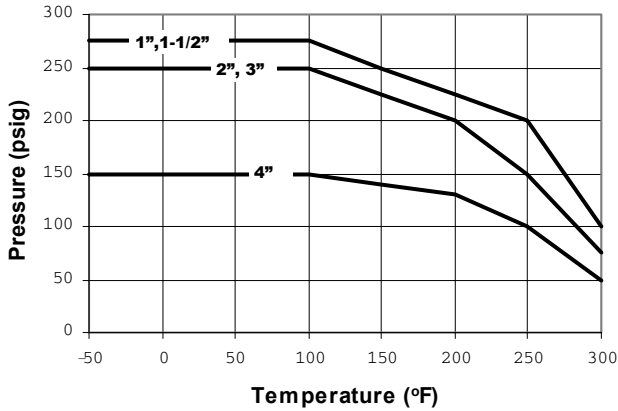

Installation Dimensions

SIZE	A	B	C	D	E	F	G	H	J	K	K (QTY)	L	M
1"	5.00	.88	1.00	2.25	3.13	4.25	.88	2.50	3.08	.62	4	2.77	6.25
1-1/2"	6.50	1.25	1.50	3.00	3.88	5.00	1.00	3.25	3.73	.62	4	3.55	6.25
2"	7.00	1.50	2.00	3.66	4.75	6.00	1.00	3.50	4.18	.75	4	3.96	9.00
3"	8.00	2.31	3.00	5.00	6.00	7.50	1.36	4.00	5.58	.75	4	5.42	9.00
4"	9.00	3.00	4.00	6.19	7.50	9.00	1.50	4.50	7.05	.75	8	6.50	11.44

Actuation Mounting Dimensions

Actuation Torque (in-lbs.)

Valve Size	N	P	R x (deep ¹)	S	T	U (+.000-.010)	V (+.000-.010)	Actuation Torque (in-lbs.)			Flow Coeff. Max. Cv	Weight (lbs.)
								Valve Running Torque ⁽²⁾	Breakaway Torque ⁽³⁾			
									0-100 psi	100-275 psi		
1	4.18	1.75	5/16 - 18 x 1/2	0.64	0.50	0.375	0.500	90	140	160	75	3
1-1/2	5.62	1.75	5/16 - 18 x 1/2	1.05	0.70	0.375	0.500	125	190	230	115	6
2	6.18	2.25	5/16 - 18 x 5/8	0.96	0.75	0.375	0.625	150	230	270	135	8
3	7.12	3.50	3/8 - 16 x 3/4	1.67	0.75	0.500	0.875	370	570	680	350	14
4	8.00	4.00	7/16 - 14 x 7/8	2.00	1.13	0.750	1.000	680	1040	1250	540	23

- (1) Minimum thread engagement required to develop design joint strength on the actuator mounting pad (composite valve body).
- (2) Flowing fluid, ball in motion between 0 and 90 deg.
- (3) Maximum breakaway torque for clean liquid service.