

TECHNICAL SPECIFICATIONS

DIN PN 10 DIN PN16

Full Face Wafer Butterfly Valves: 3"– 8"
Series 310 Fiberglass Reinforced Vinyl Ester



1. SCOPE

Full Face Wafer Butterfly Valves with through-drilled flange bolt holes for corrosive chemical service used in construction of pressurized piping systems requiring DIN flange connections.

2. SERVICE RATING

Continuous temperature service from -50 to 250° F. Short-term exposures to 300° F are acceptable.

Pressure ratings are as shown on P/T chart on reverse side of this page.

3. MATERIALS OF CONSTRUCTION

- (1) **Body:** Glass fiber reinforced vinyl ester resin
- (2) **Disc:** Graphite fiber reinforced vinyl ester resin
- (3) **Seat:** Viton GF or PTFE.
- (4) **Stem:** 17-4 PH stainless steel with molded Graphite fiber-reinforced vinyl ester on all wetted surfaces. Hastelloy-C insert is optional.
- (5) **Gland:** Hastelloy-C.
- (6) **Gland Bolts:** Hastelloy-C
- (7) **Packing:** Virgin PTFE adjustable V-rings.
- (8) **Disc Spacer:** Graphite fiber-reinforced Kynar (PVDF).
- (9) **Stem Pin:** Graphite reinforced Kynar (PVDF).
- (10) **Through-Flange Holes:** Flange bolt holes without threads allow easy alignment with line flanges.

4. DESIGN

- Body shall have flange bolt alignment holes drilled or molded through, without threads.
- Face-to-face dimensions shall be as shown on Page 2.
- Stems shall be of blowout proof design.
- Packing shall be adjustable V-ring type.
- Valve design shall be such that it can be bolted into a standard PTFE-lined steel pipe and the valve disc not interfere with the lining of the pipe.
- Valve seat and disc geometry shall provide a 360° uninterrupted bubble tight seal from full vacuum to rated valve pressure
- Gear or lever handle shall be available on all sizes.
- Valves shall be capable of on-off actuation or modulating control with pneumatic, electric or hydraulic actuators.

5. QUALITY ASSURANCE

- The Manufacturer's facility shall be certified to ISO 9001 or equivalent. The Manufacturer shall be certified to the European Pressure Equipment Directive (PED) and the "CE" mark shall be affixed to each valve label.
- Each valve shall be hydrostatically tested with water at 225 psig with the disc open and both ends blanked for 3 minutes with no evidence of leakage.
- Each valve shall be subjected to a hydrostatic seat test at not less than 110% of the rated shutoff pressure and an air test at 20 psig with no evidence of leakage.

6. PACKING AND SHIPPING

Valves shall be shipped in the closed position. Each valve shall be marked with the manufacturer, size, series, construction materials, serial number, and valve component designation.

7. AVAILABILITY

Valves meeting this specification are available from:

Nil-Cor®, LLC
12241 Rockhill Avenue, NE
Alliance, Ohio 44601
(330) 823-0500
www.nilcor.com

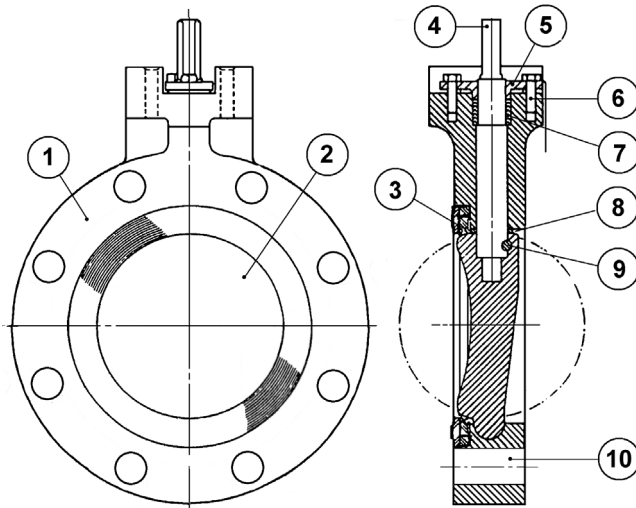

Nil-Cor FULL FACE BUTTERFLY VALVE DIMENSIONS

All dimensions are in inches unless otherwise noted

DIN PN 10, 16

2 HOLES 3/8-16 X 0.83 DEEP FOR 10-POS. PLATE
2 HOLES 0.41 DIA. THRU HOLES STRADDLE CL ON "P" BOLT CIRCLE

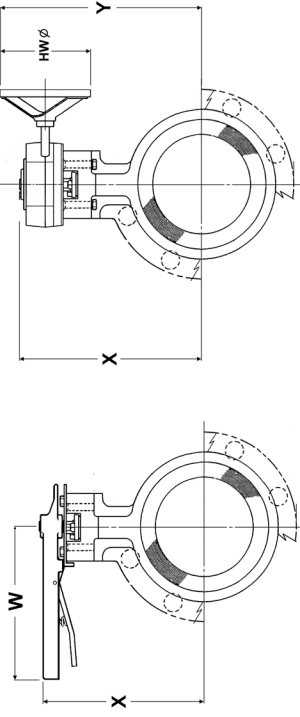

Maximum Shutoff Pressure vs. Temperature
NIL-COR BUTTERFLY VALVES

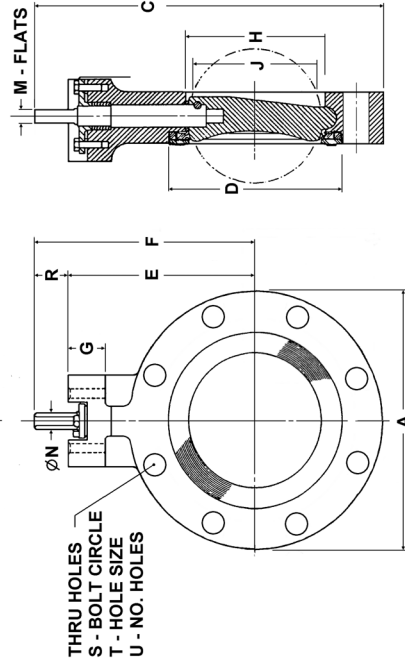
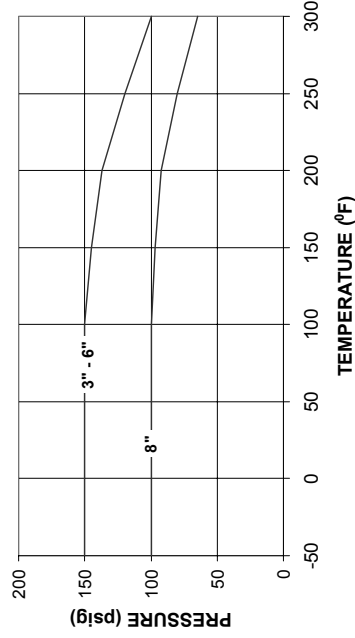

SIZE	A	B	C	D	E	F	G	H	J	K	L
3	7.50	2.06	11.31	4.13	6.38	7.56	1.50	3.13	2.38	3.13	3.50
4	9.00	2.30	13.31	5.45	7.13	8.81	1.50	4.13	3.39	3.63	4.00
6	11.00	2.45	15.18	7.45	8.13	9.68	1.63	6.13	5.43	3.63	4.00
8	13.50	2.61	18.13	9.53	9.50	11.38	1.63	8.13	7.54	3.63	4.00

SIZE	ACTUATOR MOUNTING DIMENSIONS				FLANGE BOLTING DIMENSIONS			LEVER DIMENSIONS			GEAR DIMENSIONS			OPERATING TORQUE (IN-LBS)		WEIGHT (LBS.)	
	M (+0.000 -0.002)	N	P	R	S	T HOLE SIZE	U	W	X	Y	HW	Cv	<50 psid	>50 psid	BARE	W/LEVER	W/GEAR
3	0.266	0.38	2.66	1.18	6.299	0.709	8	9.00	7.56	6.00	6.00	220	240	240	5.0	6.0	9.5
4	0.391	0.47	3.25	1.68	7.087	0.709	8	12.00	8.81	6.00	6.00	395	360	480	8.5	9.0	12.0
6	0.562	0.69	3.25	1.55	9.449	0.866	8	14.00	9.68	6.00	6.00	950	780	960	12.5	16.5	17.0
8	0.594	0.75	3.25	1.88	11.614	0.866	Note 1	14.00	11.38	7.38	9.00	2250	1680	2160	19.0	23.0	26.0

Note 1: PN10 has 8 bolt holes; PN16 has 12 bolt holes