

# TECHNICAL SPECIFICATIONS

Wafer Ball Valve

Size 8"

Series 300 / 500XP / 610XP



## 1. SCOPE

Flangeless Wafer ball valves for corrosive chemical service used in construction of pressurized piping systems.

## 2. SERVICE RATING

Temperature rating from -50 to 300° F as shown on pressure/temperature chart on the reverse side. See Catalog 1000 and Catalog 1000-Supp for temperature limits for specific chemicals.

## 3. MATERIALS OF CONSTRUCTION

### (1) Body:

Series 300: Graphite fiber reinforced vinyl ester resin.  
Series 500XP: Graphite fiber reinf. novolac epoxy resin.  
Series 610XP: Glass fiber reinf. novolac epoxy resin.

### (2) Gland: Hastelloy-C with integral locking plate.

### (3) Stem: Solid Hastelloy-C

### (4) Gland Bolts: Hastelloy-C

### (5) Stem Packing: PTFE V-Rings.

### (6) Thrust Washer: Glass and carbon-filled PTFE.

### (7) Insert: Same material as body construction (above).

### (8) Seals: PTFE-coated Viton O-ring.

### (9) Ball: Same materials as body construction (above)

### (10) Seats: Virgin PTFE. Cavity-filler seats available.

### (11) Handle Adapter: Stainless Steel handle adapter with locking provision.

### (12) Pipe Handle: Stainless Steel pipe inserts into Adapter. Gears available.

## 4. DESIGN

- Valves shall be wafer design with a face-to-face dimension of 10.00"
- Body shall be suitable for bolting between ANSI CLASS 150 flanges.
- Valve shall have integral 4-bolt mounting pads with molded threads for actuator mounting.
- Stems shall be blowout proof.
- Valves shall have a regular port.
- Valve ends shall be serrated and dimensionally compatible with metallic, lined metal, FRP, and thermoplastic piping systems.
- Disassembly, maintenance and replacement of any parts shall not require machining or bonding.
- Ball and stem strength shall be sufficient to operate with abrasive particles filling the cavity.

## 5. QUALITY ASSURANCE

- The Manufacturer's facility shall be certified to ISO 9001 or equivalent. The Manufacturer shall be certified to the European Pressure Equipment Directive (PED) and the "CE" mark shall be affixed to each valve label.
- Each valve shall be hydrostatically shell tested at no less than 1.43x its rated cold working pressure for 3 minutes.
- Each valve shall be seat tested with air at 20 and 80 psig, or with water at 1.1x rated CWP. The seat test pressure shall be applied successively to each end of the closed valve with the other end open to the atmosphere. No visible leakage shall be permitted for the duration of the tests.

## 6. PACKING AND SHIPPING

Valves shall be shipped in a closed position with both ends capped to exclude dirt and properly boxed to avoid damage. Each valve shall be marked with the manufacturer, valve size, model, serial number, and valve component designations.

## 7. AVAILABILITY

Valves meeting this specification are available from:

Nil-Cor®, LLC  
12241 Rockhill Avenue, NE  
Alliance, Ohio 44601  
(330) 823-0500  
[www.nilcor.com](http://www.nilcor.com)

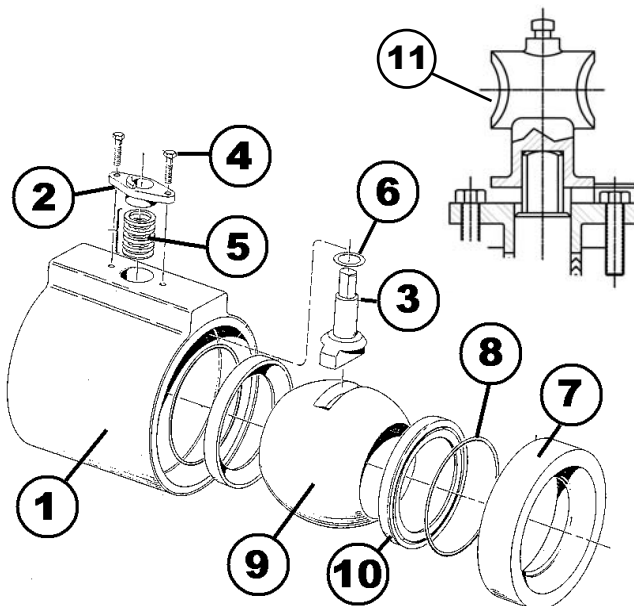

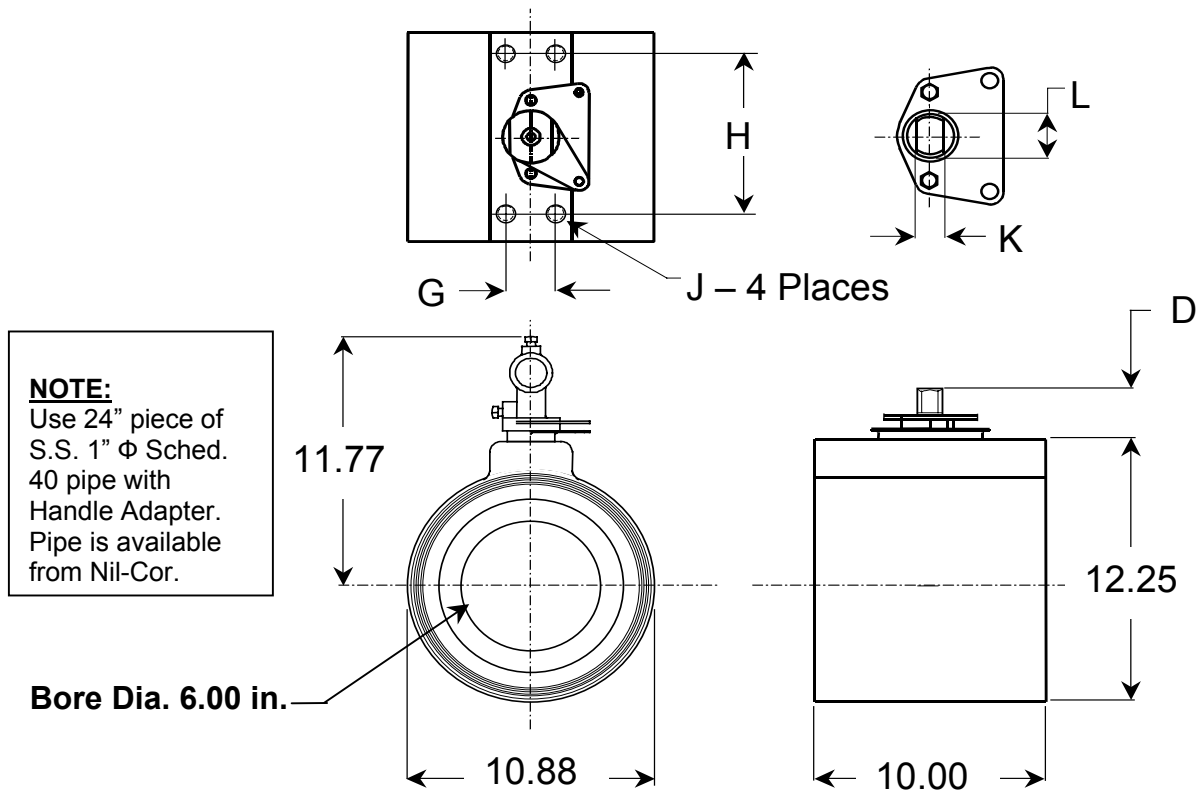

ACTUATOR MOUNTING DIMENSIONS (in.)							OPERATING TORQUE (in-lbs.)				
Valve Size	D	J x (deep)	G	H	K +0.000- .010	L +0.000- .010	Valve Running Torque	Breakaway Torque		Flow Coeff. Max. Cv	Weight (lbs.)
								0-100 psi	100-150 psi		
8"	2.32	7/16-14 x 1-1/4	1.75	7.13	0.75	1.00	2700	4200	4800	2200	41

**Pressure/Temperature Rating  
8" Wafer Ball Valve**

