

GENERAL DESCRIPTION

The Robertshaw Model 563A Vibraswitch Electronic Monitor is a microprocessor based supervisory control system designed for use with Robertshaw Model 365 or 366 Vibraswitch Malfunction Detectors. It may be used with one to eight Vibraswitches and has been programmed to provide a means of differentiating between valid excessive vibration and excessive vibration resulting from temporary external disturbances.

Many machines, during their normal operation, will suffer occasional short-duration transient shocks, which are external to the monitored machine. Examples of these disturbances are: Closing of pipeline check valves on pumping applications; Start-up of additional pumps on a line; nearby machinery operating - such as hydraulic presses, etc.. These disturbances may cause a Vibraswitch to "trip out" if the vibratory level is in excess of its setpoint. The Model 563A provides field settable Monitor Time Delay circuitry that eliminates equipment shutdown because of these transients and ensures that only a continuous vibration level which exceeds the setpoint of the Vibraswitch will initiate an alarm and/or shutdown. This Monitor Time Delay is adjustable, using digital rotary switches, over a range of 0 to 99 seconds.

Nearly all rotating machinery, during its "start-up" operation, will go through an excessive vibration point which is inherent to the machine. This vibration level sometimes is higher than the alarm/shutdown level desired for safe protection. The Model 563A contains circuitry which provides a Starting Time Delay to disable the Vibraswitches for a period of time to allow the machine to reach its normal operating speed or condition. After this delay period, the Model 563A activates the Vibraswitches to provide the necessary vibration protection. The Start Time Delay is adjustable over a range of 0 to 999 seconds by means of digital rotary switches.

Eight LED indicators, viewable through the window on the instrument door, are provided for visual indication to determine which Vibraswitch detected the excessive vibration and triggered the alarm and/or shutdown.

The supply power for the Vibraswitch Electronic Monitor is available as:

- 120 VAC
- 240 VAC
- 48 VDC
- 24 VDC

Vibraswitch Electronic Monitor Model 563A



FEATURES AND BENEFITS

- **Microprocessor Based-**
Provides greatest reliability and most accurate operation.
- **Multiple Vibraswitch Sensors-**
Monitors from 1 to 8 Vibraswitches.
- **AC or DC Supply Power**
- **NEMA 4 and Explosion-Proof Enclosures Available**
- **Field Selectable Timing Periods**

FUNCTIONAL DESCRIPTION

The Model 563A is a microprocessor based instrument that monitors one to eight Vibraswitches. It monitors the Vibraswitches to determine the occurrence of excessive vibration and then integrates this vibration time. If the duration of the excessive vibration exceeds the preset limits, an alarm and/or shutdown condition is generated by a set of relay contacts.

The Start Time Delay circuitry inhibits monitoring from the time a machine is first started until it reaches its normal operation speed and condition. This time is adjustable from 0 to 999 seconds by means of three digital rotary switches. The leftmost switch indicates hundreds of seconds, the middle switch indicates tens of seconds, and the right switch indicates individual seconds. When the machine power monitor voltage (normally supplied by the start circuit of the machine) is applied to TB-10 and goes from OFF to ON, the Start Time Delay is initiated. It can also be initiated by pressing and releasing the Pushbutton Indicator on the door of the instrument. This delay is terminated at the end of the time period specified by the settings of the Start Time Delay switches. At the end of the Start Time Delay period, the Model 563A will reset all Vibraswitches (if required) and commence to monitor them for excessive vibration.

A Monitor Time Delay period is initiated when any Vibraswitch trips from excessive vibration. The Monitor Time Delay period is adjustable from 0 to 99 seconds by means of two digital rotary switches. If the vibration continues to the end of this period, the alarm and/or shutdown contracts will actuate and the red indicator within the Reset Button on the instrument door will turn ON. The voltage applied to this indicator will also be applied to terminals 6 and 7 of TB-9 for an optional remote alarm indicator. When this condition occurs, an internal LED will come ON. The operator can determine which Vibraswitch tripped and cause the alarm and/or shutdown event by observing these eight LED's.

The Monitor Time is actually an integrated time period. The period is divided into five (5) sampling segments. When excessive vibration occurs within a segment, a counter is incremented one unit. If no excessive vibration occurs during a sampling segment, the counter is decremented one unit. The counter is never negative so it is either decremented or remains at zero count when there is no excessive vibration. If the counter reaches a count of five and excessive vibration occurs before it is decremented, an alarm and/or shutdown condition is generated.

After an alarm and/or shutdown condition occurs, the alarmed Vibraswitch will remain tripped until a complete "restart" is initiated or the Reset Button on the Model 563A cover is pressed and released, which will cause the reset of ALL Vibraswitches and the reset of the internal circuitry to the initial "Start-up" conditions. This action also returns the alarm/shutdown contacts to their normal state and turns off the red indicator light and LED.

The Start Time Delay and the Monitor Time Delay setpoint switches and the eight LED's are visible through the window on the door so that an observer can determine the condition of the individual Vibraswitches and the delay settings.

SPECIFICATIONS

PERFORMANCE

Timing Accuracy± 5% @ 68°F

Timing Range:

Start Delay 0 to 999 Seconds

Monitor Delay 0 to 99 Seconds

Setting Resolution 1 Second

ENVIRONMENTAL

Temperature:

Operating -40°F to +160°F
(-40°C to 72°C)

Storage -55°F to +225°F
(-49°C to +107°C)

Vibration Limits 0.5G 15 to 100 Hz

Relative Humidity 95% at 100°F

ELECTRICAL

Supply Voltage:

Model 563A-A 120 VAC ± 10%, 50/60 Hz
150 Watts, 167 VA Maximum

Model 563A-B 240 VAC, ± 10%, 50/60 Hz
150 Watts, 167 VA Maximum

Model 563A-C 24 VDC, ±10%
150 Watts Maximum

Model 563A-D 48 VDC, ± 10%
150 Watts Maximum

Machine Power Monitor:

Voltage Same as supply voltage

Amperage Less than 20 mA

Alarms/Shutdown Contacts:

(Terminals 3, 4 & S on TB-9) 5 Amp, 28 VDC
and 120 VAC & 240 VAC non-inductive

Remote Alarm Indicator (TB-9):

Maximum load is 25 watts

Terminals 6 & 7 Output is 120 VAC, 1 /2 wave
Also TB-8 Terminals 5 & 6..... rectified or the

DC supply voltage

Remote Reset

Open circuit voltage is 12 Volts Maximum

Short circuit current is 0.1 Amp Maximum

Terminals 1 & 2 TB-9

USER CONNECTIONS

TB-1 through TB-8 may be connected to one or more Vibraswitches, up to a maximum of eight. Vibraswitch terminals 1 through 4 are connected to terminals 1 through 4 respectively on TB-1 through TB-8. Terminals 5 and 6 on each TB are connections for optional remote indicators, if desired. Any combination of TB's may be used if less than eight Vibraswitches are used. For example if only three Vibraswitches are used, it may be more convenient to connect them to terminal blocks 5,6 and 7.

The Vibraswitches used with any Model 563A must have reset coils with voltages identical to the primary supply voltage of the Model 563A EXCEPT Vibraswitches used with the 240 VAC version which must have a reset coil voltage of 120 VAC.

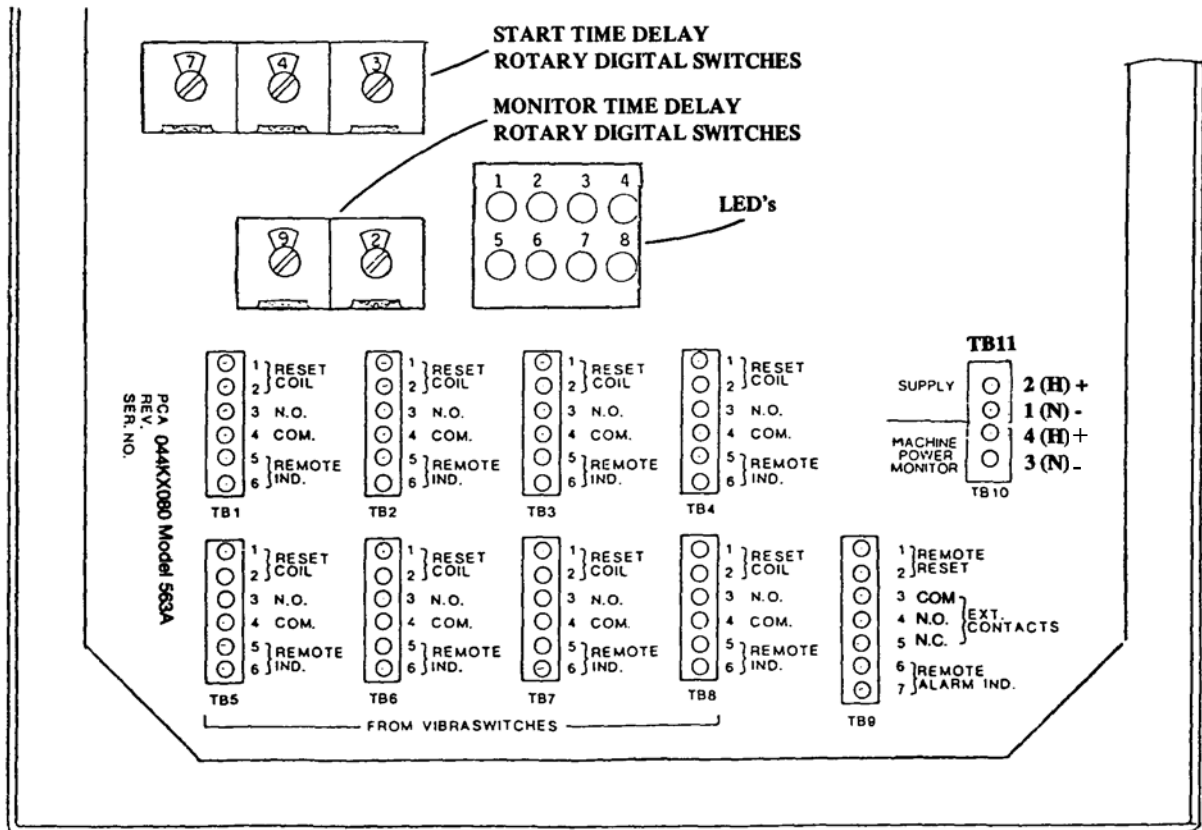

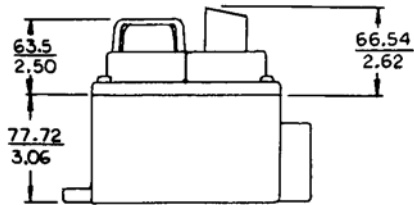
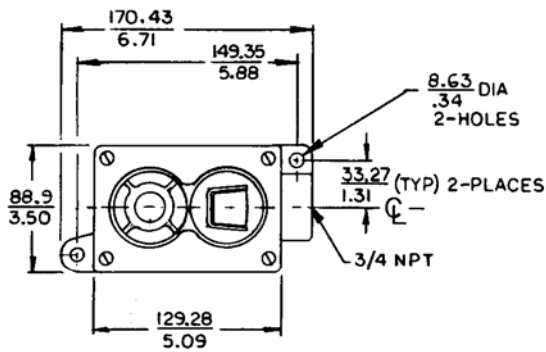

SINGLE GANG
RESET PUSHBUTTON
AND RED PILOT L16HT
COMBINATION
DEAD END

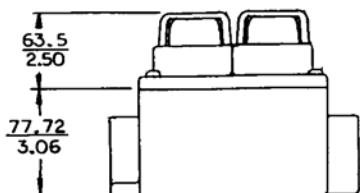
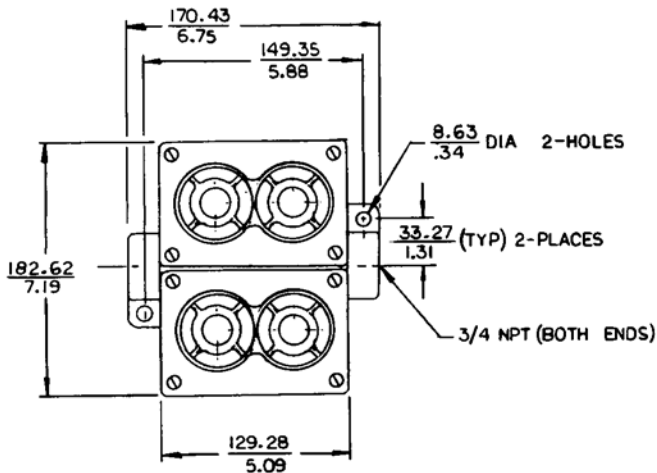

TWO GANG
DOUBLE PILOT LIGHT
EACH GANG,
4-RED PILOT L16HTS
THROUGH FEED



ORDERING INFORMATION

Specify complete model number according to the tables below.

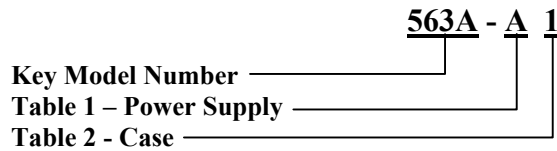

KEY MODEL NUMBER

Model No.	Description
563A	The Model 563A Vibraswitch Monitor is a microprocessor based device programmed to differentiate between valid and invalid vibration alarms. Can be used with one to eight Vibraswitch Malfunction Detectors.

Table 1 - POWER SUPPLY

Designation	Description
A	120 VAC, 56/60 Hz
B	240 VAC, 50/60 Hz
C	24 VDC
D	48 VDC

Table 2 - CASE

Designation	Description
1	Weather-proof, NEMA 4
2	Explosion-proof, meets Class I, Division 1, Groups C & D
3	NEMA 4X, Steel, Painted with Gray Epoxy Enamel
4	NEMA 4X, Stainless Steel

ACCESSORY ITEMS*

Part No.	Description
190KB083-01	Reset Pushbutton and Alarm Indicator for use with 563A-A/ B ()
190KB083-02	Four Alarm Indicators for use with 563A-A/ B ()
190KB083-03	Reset Pushbutton and Alarm Indicator for use with 563A-D ()
190KB083-04	Four Alarm Indicators for use with 563A-D ()
190KB083-05	Reset Pushbutton and Alarm Indicator for use with 563A-C ()
190KB083-06	Four Alarm Indicators for use with 563A-C ()

* Suitable for use in Class I, Division 1, Groups C & D locations.

WEATHER-PROOF (NEMA - 4) DESIGNED FOR SURFACE MOUNTING

ENCLOSURES

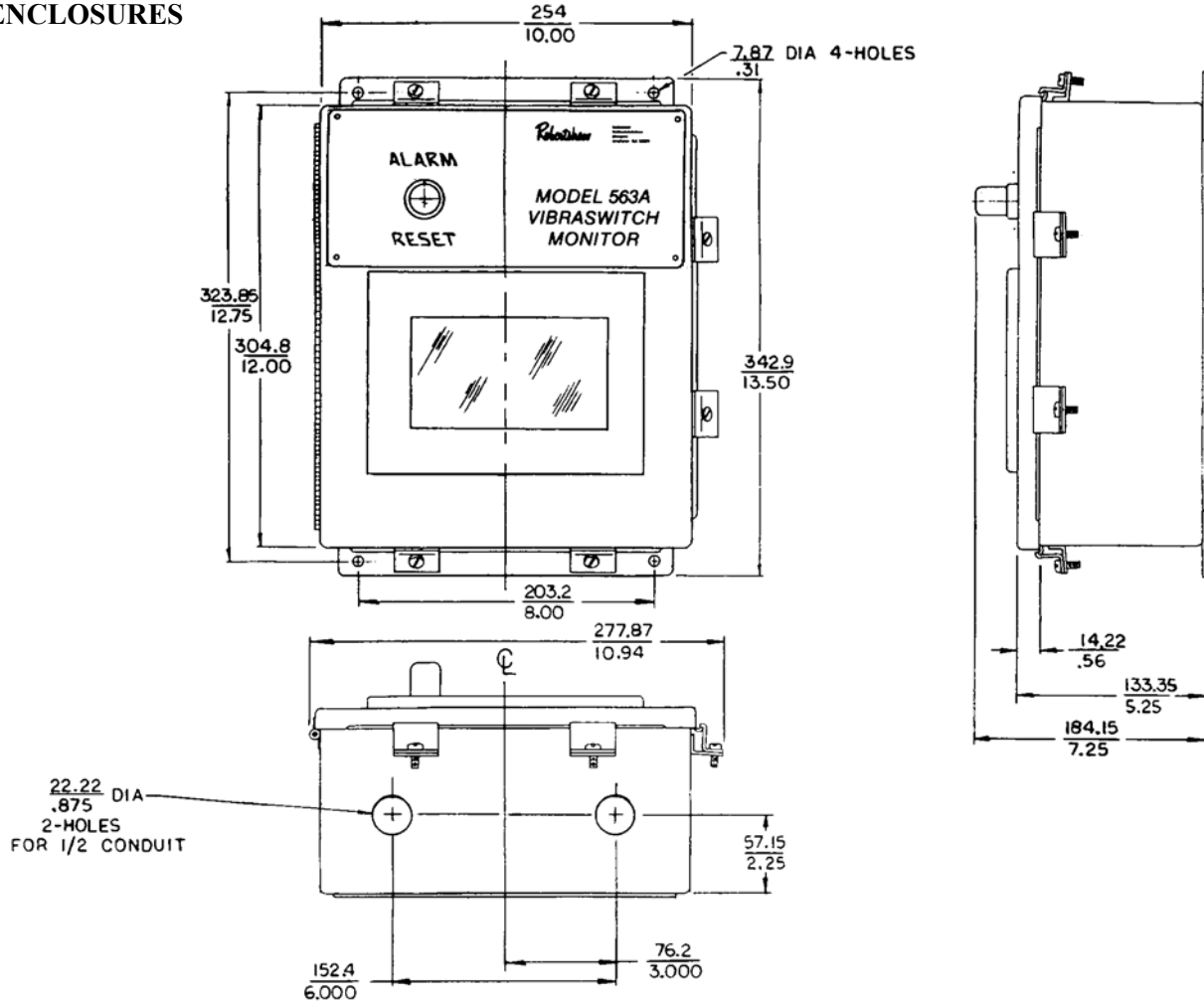

EXPLOSION-PROOF HOUSING (MEETS CLASS 1, DIV 1, GROUPS C & D)

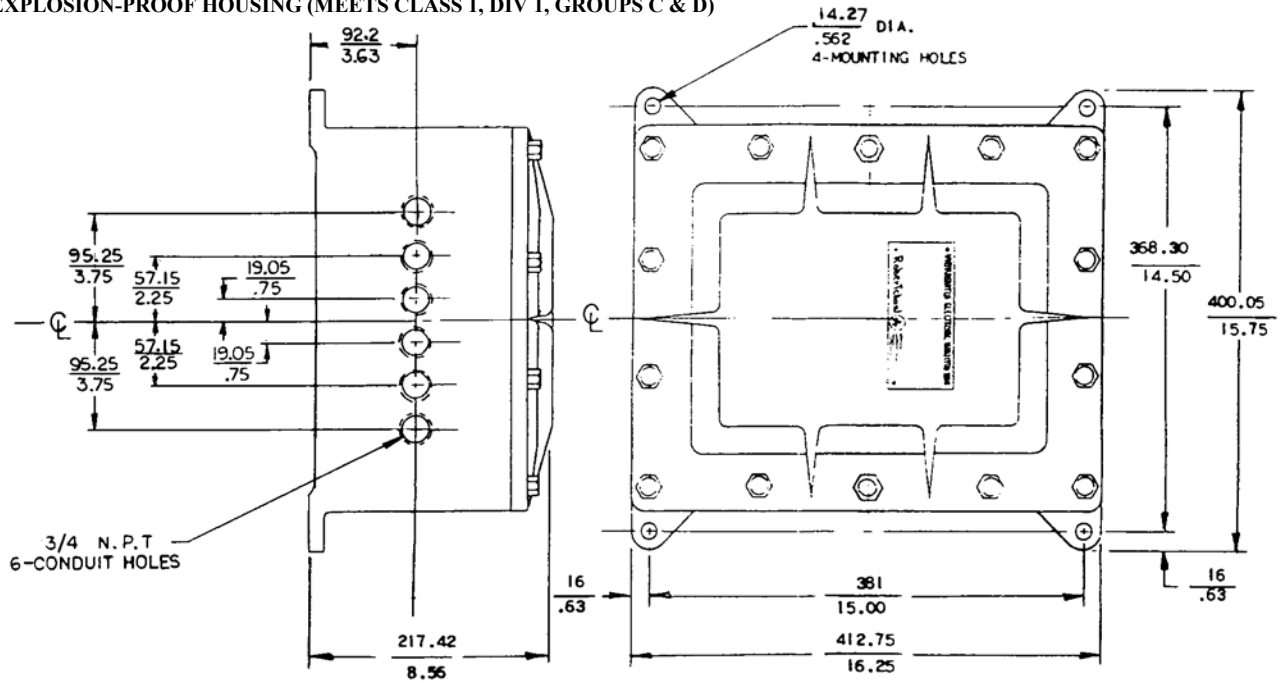

Robertshaw

For Spain:
IPIC GSP S.L.
Plaza Calvo Sotelo 3
03001 Alicante (Spain)
Telephone: (34) 965 213878 Fax: (34) 965 206412 ipic@ipic-gsp.com